

SPECIFICATION

SPEC. No. _____

DATE: _____

To

CUSTOMER'S PRODUCT NAME

TDK'S PRODUCT NAME

Ceramic insulated capacitors disc type class 1

TYPE : CC45SL3△DOOOJY◇NA

RECEIPT CONFIRMATION

DATE: _____ YEAR _____ MONTH _____ DAY _____

TDK Corporation

Sales

Electronic Components Sales &
Marketing Group

Engineering

Ceramic Capacitors Business Group .

APPROVED	Person in charge

APPROVED	CHECKED	Person in charge

Handling precautions for High voltage ceramic capacitors

Please read the following closely before using these products.

Safety precautions

The following precautions should be observed strictly to ensure safety design.

Misuse of the product may lead to smoking of the product.



Cautions

1. Operating voltage

Use within the rated voltage of capacitor between terminals. For DC rated voltage application, you should control the peak voltage (V_{0-P}) under the rated voltage in case the AC voltage is superimposed on the DC voltage. Use within the rated voltage includes peak voltage (V_{P-P}) when AC voltage or impulse voltage applied in a circuit. Confirm irregular voltage (surge voltage, static electricity, switching noise, etc) occurs in the equipment used, and use within the rated voltage containing the irregular voltage.

When the capacitor is used as a noise suppressor in the AC primary circuit, the voltage proof test should be within the specified conditions (voltage, time, wave form, etc).

Connect by confirmation of non lose contact, and the voltage is started to apply to the circuit from zero to the specified voltage and it is stopped applying from the voltage to zero.

Voltage	(1) DC voltage	(2) DC+AC voltage	(3) AC voltage	(4) Pulse voltage
Voltage Measuring position				

2. Operating temperature

Be sure to use only those operating temperature described in our catalogue or specification.

Keep the surface temperature under the maximum temperature, which includes the maximum self-heat temperature of 20 degree C.

3. Self-exothermal

Self-exothermal temperature should be within 20 degree C on the condition of atmosphere temperature 25 degree C without the influence of wind such as the cooling fan. Be sure to use a capacitor in a circuit of current increase by AC voltage or pulse voltage applied.

When high frequency voltage or impulse voltage applied in a circuit, reliability should be influenced.

Take into considerations the load reduction and self-exothermal temperature, even if voltage should be within the rated voltage.

PLP Spec No.

HV095F19



Cautions

4. Capacitance change of capacitors

For some of the capacitors, capacitance value may change considerably in the temperature range, or by applied DC voltage. And capacitor has aging characteristic (capacitance decreases by keeping as it is). When you use the capacitor in the time constant circuit, consult TDK whether the capacitor is available or not.

5. Vibration of capacitors

When the capacitor class 2 is used in the AC circuit, or pulse circuit, the capacitor might vibrate or noise might occur in the specified frequency. Be sure to confirm the conditions before using the capacitor.

6. Usage of capacitance and storage

Don't use capacitors in the following environments:

- * Direct sunshine
- * Areas directly exposed to water or salty water
- * Areas that become dewy
- * Areas filled with toxic gases (such as hydrogen sulfide, sulfur dioxide, chlorine, ammonia, etc)
- * Areas exposed to excess vibrations or shock conditions described in our catalogue or specification.

Store capacitors in an environment from -10 to 40 degree C, with 15 to 70%RH for 6 months maximum and use within the period after receiving the capacitors.

7. Inserting precautions

When inserting capacitors into the PC board by automatic insertion machine, confirm the conditions (such as pressure of pusher, adjustment of clinching portion) and minimize the impact force by chucking the body, or clinching the lead terminals.

Distances between the hole position onto a PC board should be equal to the pitch of capacitors.

When stretching the lead terminal, any force may load the bottom of the capacitor body and result in damage to the insulation coating. Severe damages may cause poor reliability.

8. Soldering

Don't immerse the capacitor body into the molten solder, and don't solder the terminals by reflow soldering. Use PC board, and solder the terminals in the opposite side of the body. Soldering conditions, such as pre-heat temperature, soldering temperature, and soldering time, should be followed by the descriptions in our catalogue or specification. (refer to Fig.-1)

Adjust the amount of solder within the proper volume. Select an appropriate soldering material.

When using soldering iron for installing capacitors or reworking onto the PC board, sufficient pre-heating and temperature control should be used. We recommend that the iron condition is 350 ± 10 degree C/ 3.5 ± 0.5 s. as 1 time, and you should use an adequate tip diameter ($\phi 3$ mm Max.) with the soldering iron as well as a proper wattage (50W Max.). Don't touch the capacitor body directly with soldering tip, except for the terminals of capacitor.

9. Flux

When using flux for soldering capacitors onto the PC board, spread it thinly and uniformly.

Flux will be composed of halogenated material less than 0.1 wt% (cl conversion).

Don't use a strong acid grade of flux. When using water-soluble flux, sufficient cleansing should be done.

PLP Spec No.

HV095F19



Cautions

10. Cleansing

When the cleansing should not be sufficient, the cleansing liquid or any residue might leave on the capacitor body, they may deteriorate the insulation coating or performance (insulation resistance, etc.). When using ultrasonic cleansing, avoid transmitting vibrations onto the PC board. Conditions of ultrasonic cleansing, such as output frequency and time of the method, should be taken into considerations.

After cleansing capacitors, dry them well. Cleansing liquid should not contain electrolyte, nor leave any residue. Through the result of the cleansing method, confirm whether the quality of the capacitors have been affected due to the conditions.

11. Coating or molding

When coating or molding capacitors after installing components onto the PC board, confirm whether the performance of capacitors may not be damaged by the work.

12. Mechanical stress

Don't submit to excessive mechanical shock. Don't use capacitors which may have been damaged due to dropping, etc.

If possible, avoid bending the terminals of capacitors. In an unavoidable case of bending, use a small jig to decrease the mechanical stress on the capacitors.

13. Others

Please contact TDK before using our capacitors listed in this catalogue or specifications for the applications listed below which require especially high reliability for the prevention of defects which might directly cause damage to the third party's life, body or property, or when intending to use one of our capacitors for other applications than specified in this catalog or specifications.

- * Medical equipment
- * Aerospace equipment
- * Power plant equipment
- * Aircraft equipment
- * Transportation equipment (vehicles, trains, ships, etc)
- * Undersea equipment
- * Traffic signal equipment
- * Disaster prevention, crime prevention equipment
- * Data processing equipment exerting influence on public
- * Application of similar complexity and, or reliability requirements to the applications listed in the above.

Please refer to the guideline of notabilia for fixed ceramic capacitors issued by JEITA (Japan Electronics and Information Technology Association, EIAJ RCR-2335).

PLP Spec No.

HV095F19

Scope

This specification applies to ceramic insulated capacitors disc type used in electronic equipment.

Relative standards

JIS C 6423-1991

JIS C 5102-1994

Mention item

1. Part No.
2. Operating temperature range
3. Test condition
4. Performance
5. Marking
6. Figure & Dimension
7. Label, Packing & Transport
8. Notification before the modification

We do not use the following material (1),(2) in these products.

(1) PBBOs (Poly Bromo Biphenyl Oxides)

(2) PBBs (Poly Bromo Biphenyls)

We do not use Class I ODS (Ozone depleting substances) in all our process of these products.

These products shall conform to RoHS Directive

These products are Halogen-free.(Br \leq 900ppm, Cl \leq 900ppm, Br+Cl \leq 1500ppm)

Manufacturing place

Manufacturing site should be TDK Taiwan & TDK Xiamen

Divisio	Date Issued	SPEC. No.
Ceramic Capacitors Business Group		

1. Part No.

(Example)

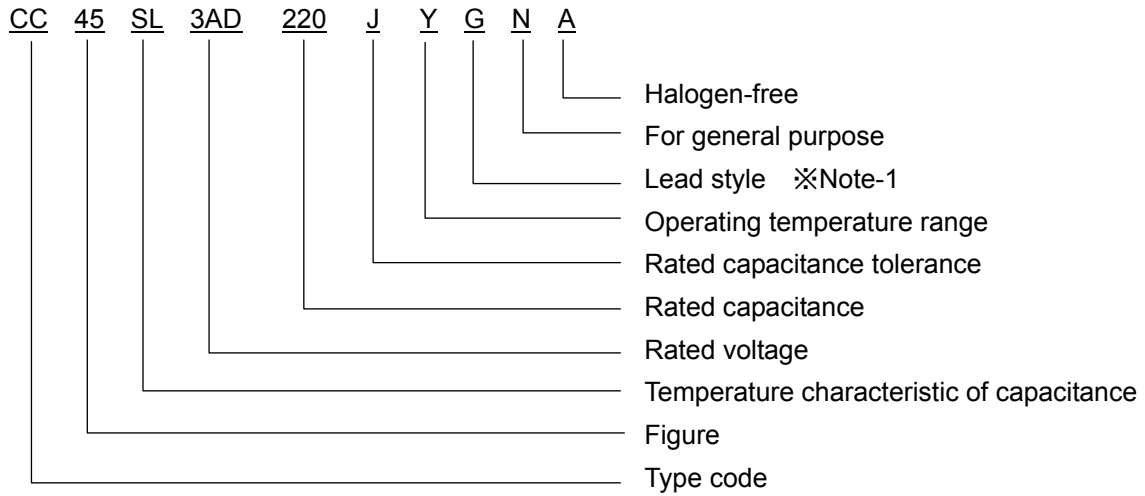

※ Note-1

Lead style G : Vertical kink long lead (Bulk)
 N : Vertical kink short lead (Bulk)
 V : Vertical kink long lead (Taping)

2. Operating Temperature range : -25 °C to +125 °C ※ Note-2

※ Note-2 Operating temperature range max. is +125 °C
 (Including capacitor's self-heating max. +20 °C)

3. Test condition

Test and measurement shall be made at the standard condition, (Temperature 15 to 35 °C, relative humidity 45 to 75 % and atmospheric pressure 860 to 1060 hPa.), Unless otherwise specification herein. If doubt occurred on the value of measurement, and remeasurement was requested by customer capacitors shall be measured at the reference condition (Temperature 20 ±2 °C ,relative humidity 60 to 70 % and atmospheric pressure 860 to 1060 hPa.)

4. Performance

The performances shall comply with Table-1

Table-1

No	Items		Performance	Test method								
1	Appearance and dimension		The appearance and dimension shall be as given in paragraph 6 and Table-2 to 5	Visual check and measuring with Micrometer.								
2	Marking		The marking shall be easily legible (Paragraph 5)	Visual check								
3	Withstand voltage	Between terminals	No failure	Twice rated voltage 1 to 5 sec. Charge and discharge current shall be 50mA or less.								
		Between terminal and exterior cladding	No failure	The metallic small ball method 1300V DC (1 to 5 sec.) Charge and discharge current shall be 50mA or less. 								
4	Insulation resistance	Between terminals	10000 MΩ or more	The insulation resistance should be measured with DC500±50V within 60±5 sec.								
5	Capacitance		With the tolerances specified with Table-3 to 5	Measuring frequency : 1MHz ±20 % Measuring voltage : 5Vrms. or less								
6	Q		$C < 30 \text{ pF} : Q \geq 400 + 20C$ $C \geq 30 \text{ pF} : Q \geq 1000$									
7	Capacitance temperature characteristic (No voltage application)		+ 350 ~ -1000 PPM/°C	The capacitance measurement should be made at each step specified in Table. temperature coefficient on the basis of a capacity level of Step 3.								
			<table border="1" data-bbox="785 1086 1485 1176"> <thead> <tr> <th>Step</th> <th>1</th> <th>2</th> <th>3</th> <th>4</th> <th>5</th> </tr> </thead> <tbody> <tr> <td>Temp.(°C)</td> <td>20 ±2</td> <td>-25 ±3</td> <td>20 ±2</td> <td>8 5±2</td> <td>20 ±2</td> </tr> </tbody> </table>		Step	1	2	3	4	5	Temp.(°C)	20 ±2
Step	1	2	3	4	5							
Temp.(°C)	20 ±2	-25 ±3	20 ±2	8 5±2	20 ±2							
8	Strength of terminal	Tensile strength	Lead wire shall not be disconnected and capacitor shall not be damaged	The force of 10N shall be applied to the axial direction of the termination.								
		Bending strength	Lead wire shall not be disconnected and capacitor shall not be damaged	The force of 5N shall be applied to the axial direction of the terminal and the body shall be inclined through an angle of 90 degrees, then the body shall be returned to the original position. Furthermore the body shall be inclined to the other direction of 90 degrees. This operation shall be carried out two times.								
9	resistance Vibration	Appearance	No marked defect	Vibration frequency range: 10 to 55Hz. Displacement: 0.75mm Total duration: 6 hours (2 hours for each direction: X,Y,Z)								
		Capacitance change	Within the tolerances specified with No.5									
		Q	Within the value specified with No.6									

Table-1 Continue

No	Items	Performance	Test method	
10	Resistance to soldering heat	Appearance	Soldering temperature: $350 \pm 10^\circ\text{C}$ / 3.5 ± 0.5 s or $260 \pm 5^\circ\text{C}/10 \pm 1$ s Dipping depth: 1.5 to 2.0mm from the bottom of lead terminal. (shielding board shall be used.)	
		Capacitance change		Within ± 2.5 %
		Withstand voltage (Between terminals)		No failure
11	Solderability	At least 3/4 of circumferential dipped into solder shall be covered with new solder.	Soldering temperature : $245 \pm 5^\circ\text{C}$ Dipping time : 2 ± 0.5 sec. Concentration of solution shall be about 25 % colophonium in weight ratio.	
12	Temperature cycle and dipping cycle	Appearance	Temperature cycles first, then dipping cycle should be tested. Temperature cycle: 5 cycles Step 1: -25°C , 30 min. Step 2: room temp., 3 min. Step 3: $+125^\circ\text{C}$, 30 min. Step 4: room temp., 3 min. Dipping cycle: 2 cycle Step 1: $+65^\circ\text{C}$, 15 min. Step 2: 0°C , 15 min. (saturated aqueous solution of salt) Precondition : pre-heat $125 \pm 3^\circ\text{C}$, 1hr, leaving room temp. for 24 ± 2 hrs.	
		Capacitance change		Within ± 10 %
		Q		$C < 30$ pF : $Q \geq 275 + (5/2)C$ $C \geq 30$ pF : $Q \geq 350$
		Insulation resistance		1000 M Ω or more
		Withstand voltage (Between terminals)		No failure
13	Moisture resistance (Steady state)	Appearance	Test temperature : $40 \pm 2^\circ\text{C}$ Relative humidity : 90 to 95 % Test time : 500 +24, -0 hours Capacitors shall be measured after leaving it under room temperature for 1 to 2hours.	
		Capacitance change		Within ± 5 %
		Q		$C < 30$ pF : $Q \geq 275 + (5/2)C$ $C \geq 30$ pF : $Q \geq 350$
		Insulation resistance		1000 M Ω or more
14	High temperature loading	Appearance	Test temperature : $125 \pm 3^\circ\text{C}$ Test time: 1,000+48,-0 hours 150% rated voltage applied. Capacitors shall be measured after leaving it under room temperature for 1 to 2hours. Charge and discharge current shall be 50mA or less.	
		Capacitance change		Within ± 5 %
		Q		$C < 30$ pF : $Q \geq 275 + (5/2)C$ $C \geq 30$ pF : $Q \geq 350$
		Insulation resistance		2000 M Ω or more
15	Moisture resistance loading	Appearance	Test temperature : $40 \pm 2^\circ\text{C}$ Relative humidity : 90 to 95 % Test time : 500 +24, -0 hours Rated voltage applied. Capacitors shall be measured after leaving it under room temperature for 1 to 2hours. Charge and discharge current shall be 50mA or less.	
		Capacitance change		Within ± 7.5 %
		Q		$C < 30$ pF : $Q \geq 100 + (10/3)C$ $C \geq 30$ pF : $Q \geq 200$
		Insulation resistance		500 M Ω or more

5. Marking

Marking on the one sides
 Mark color black or nearly colors

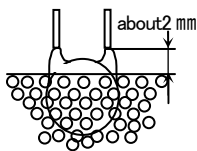
Temperature characteristic : SL

Dia : 6.0 mm Max.

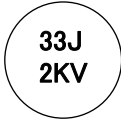
Marking item	Example
1. Rated capacitance : 33 2. Tolerance capacitance : J 3. Rated voltage : 2kV	

Dia : 6.5 mm Min.

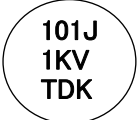
Marking item	Example
1. Rated capacitance : 101 2. Tolerance capacitance : J 3. Rated voltage : 1kV 4. Manufacture's name : TDK	

Tolerance of capacitance J : ± 5 %

6. Figure & dimension

6.1 Vertical kink long lead (Lead style: G / Bulk)

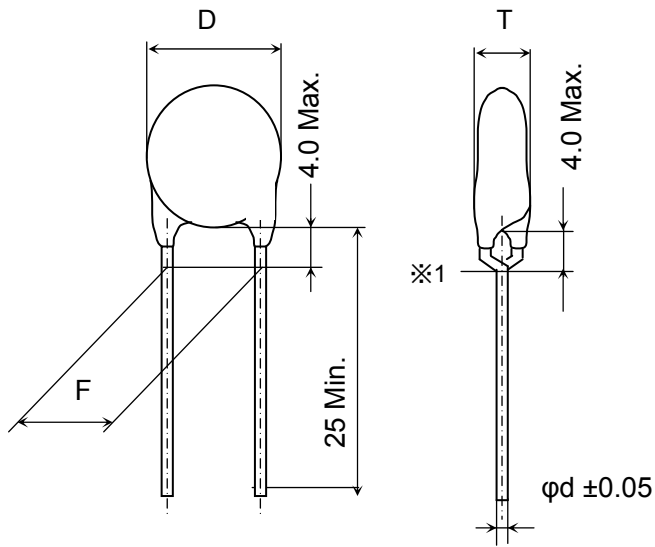

6.2 Vertical kink short lead (Lead style: N / Bulk)

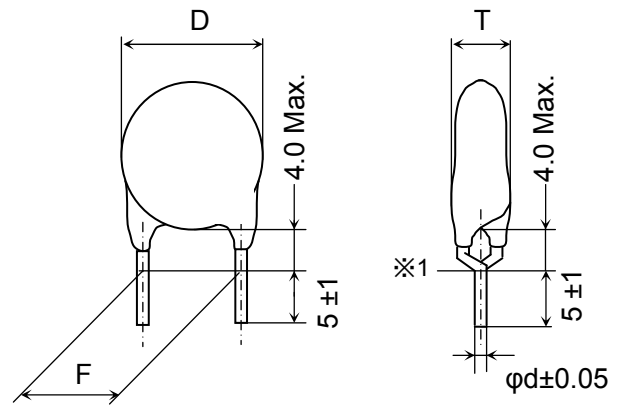

※1 Coating on lead shall not extend beyond the bottom of vertical kink.

Unit : mm

Coating material: Epoxy resin (Color: Blue)

(Flame class): UL94, V-0

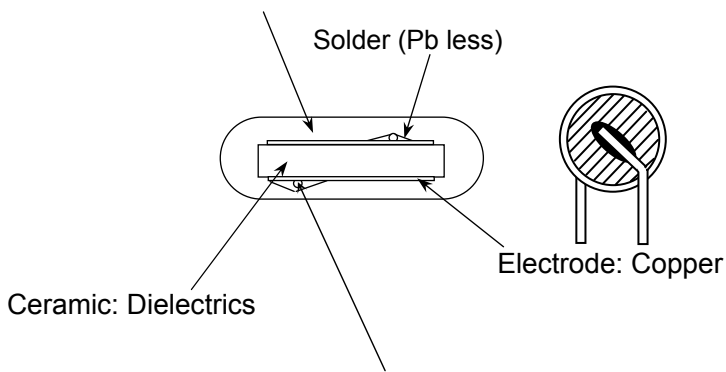

Lead wire: CP wire (Tin plated copper covers steel wire, Pb less)

6.3 Vertical kink long lead (lead style: V / Taping)

(F=5.0mm, Pitch: 12.7mm, Shape: A, at Table-3~5)

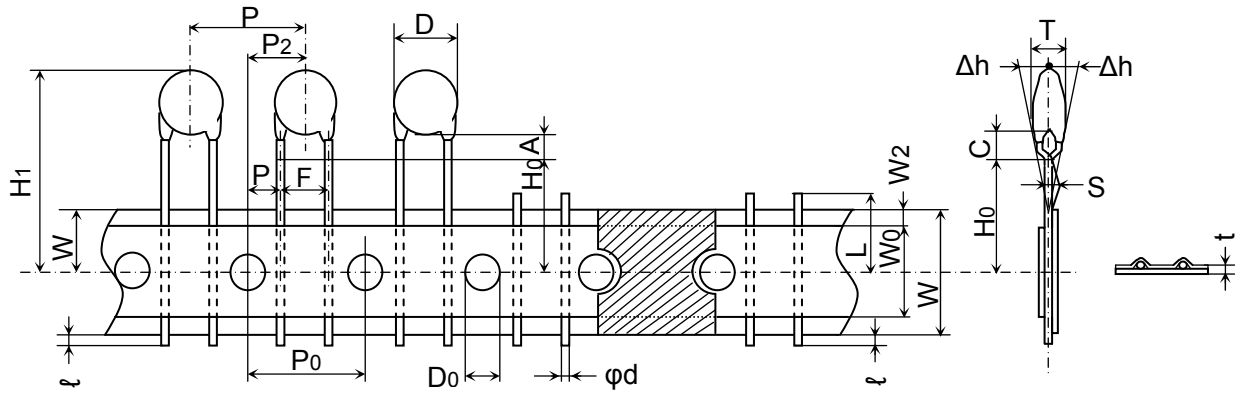

Table-2

Unit : mm

Item Name	Symbol	Dimension	Remarks
Body diameter	D	Table-3~5	
Body thickness	T	Table-3~5	
Lead-wire diameter	ϕd	0.6 \pm 0.05	
Pitch of component	P	12.7 \pm 1.0	Including the slant of body
Feed hole pitch	P_0	12.7 \pm 0.3	Excepting the tape splicing part
Feed hole center to lead	P_1	3.85 \pm 0.7	
Feed hole center to component	P_2	6.35 \pm 1.3	Including the slanting body due to bending lead-wire
Lead-to lead distanc	F	5.0 +0.8,-0.2	Measuring point is bottom kink
Component alignment, F-R	Δh	0 \pm 2.0	Including the slanting body due to bending lead-wire
Tape width	W	18.0 +1.0,-0.5	
Adhesive tape width	W_0	10.0 Min.	
Hole position	W_1	9.0 \pm 0.5	
Adhesive tape position	W_2	4.0 Max.	Adhesive tape do not stick out the tape
Bottom of kink from tape center	H_0	16.0 +1.5,-0.5	
Height of body from tape center	H_1	46.0 Max.	
Lead-wire protrusion	ℓ	1.0 Max.	
Feed hole diameter	D_0	4.0 \pm 0.2	
Total tape thickness	t	0.6 \pm 0.3	Including adhesive tape
Length of snapped lead	L	11.0 Max.	
Coating on lead	C	4.0 Max.	
Height of kink	A	4.0 Max.	Measuring point is bottom of kink
Spring action	S	2.0 Max.	

6.4 Vertical kink long lead (lead style: V / Taping)

(F=7.5mm, Pitch: 15.0mm, Shape: B, at Table-3~5)

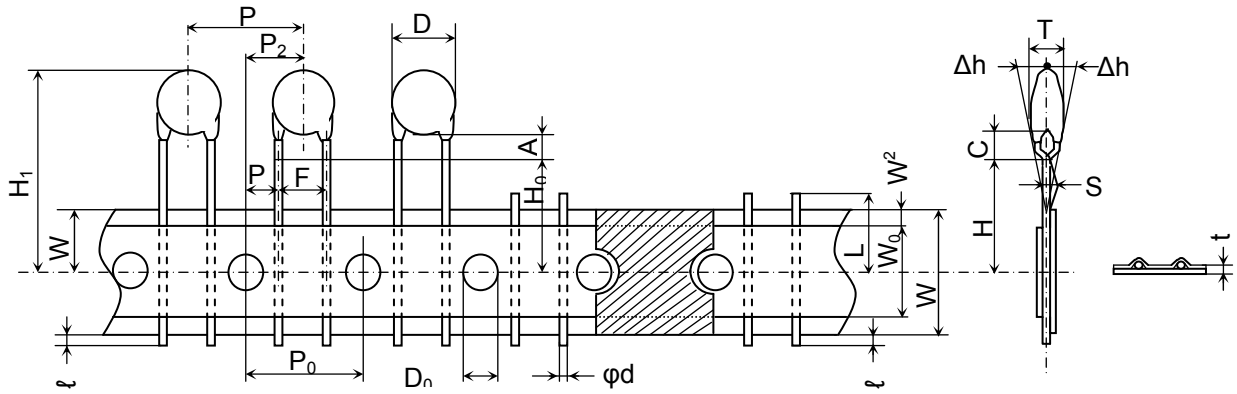

Table-2 Continue

Unit: mm

Item Name	Symbol	Dimension	Remarks
Body diameter	D	Table-3~5	
Body thickness	T	Table-3~5	
Lead-wire diameter	ϕd	0.6 \pm 0.05	
Pitch of component	P	15.0 \pm 1.0	Including the slant of body
Feed hole pitch	P_0	15.0 \pm 0.3	Excepting the tape splicing part
Feed hole center to lead	P_1	3.75 \pm 0.7	
Feed hole center to component	P_2	7.5 \pm 1.3	Including the slanting body due to bending lead-wire
Lead-to lead distanc	F	7.5 \pm 0.8	Measuring point is bottom kink
Component alignment, F-R	Δh	0 \pm 2.0	Including the slanting body due to bending lead-wire
Tape width	W	18.0 +1.0,-0.5	
Adhesive tape width	W_0	10.0 Min.	
Hole position	W_1	9.0 \pm 0.5	
Adhesive tape position	W_2	4.0 Max.	Adhesive tape do not stick out the tape
Bottom of kink from tape center	H_0	16.0 +1.5,-0.5	
Height of body from tape center	H_1	46.0 Max.	
Lead-wire protrusion	ℓ	1.0 Max.	
Feed hole diameter	D_0	4.0 \pm 0.2	
Total tape thickness	t	0.6 \pm 0.3	Including adhesive tape
Length of snapped lead	L	11.0 Max.	
Coating on lead	C	4.0 Max.	
Height of kink	A	4.0 Max.	Measuring point is bottom of kink
Spring action	S	2.0 Max.	

Note-1 Use the gummed tape to connect two ends of broken tape.

Note-2 Dropouts of parts shall be limited to no more than three consecutive parts.

Note-3 Packaging method and dimensions see below.

Note-4 Quantity $\left\{ \begin{array}{l} \text{Pitch: 12.7mm 1000 pcs. /Box.} \\ \text{Pitch: 15.0mm 1000 pcs. /Box.} \end{array} \right.$

Packaging : Ammo pack

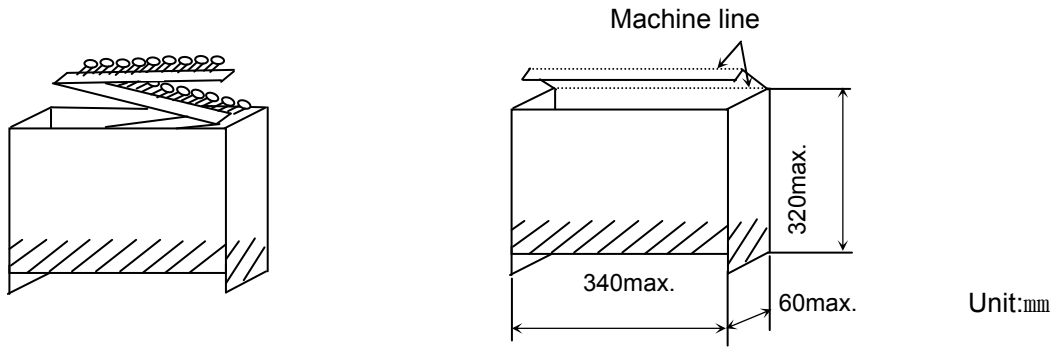

Note-5 Package of shipment

Capacitors pack in downward

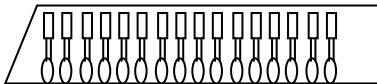

7. Label and transport

Capacitors shall be packaged prior to shipment so as to prevent damage during transportation and storage. Shipping carton contains the following information on the label.

- a) TDK item name
- b) Quantity
- c) TDK inspection number
- d) Manufacturer's name
- e) Country of origin

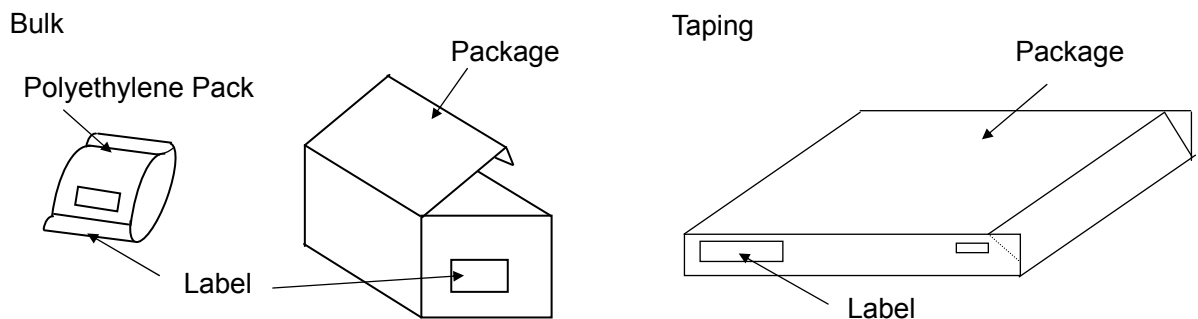

8. Notification before the modification

We'll previously notify the modified place of manufacture, manufactured articles and materials.

T.C. _____ : SL _____

Rated voltage: DC 1kV _____

Vertical kink long lead (lead style: G / bulk)

Table-3

Your part No.	TDK part No.	Cap (pF)	C-Tol. (%)	Dimension (Unit : mm)			
				D Max.	T Max.	F	φd
	CC45SL3AD100JYGNA	10	± 5	5.5	5.0	5.0 ±1.5	0.6
	CC45SL3AD120JYGNA	12	± 5	5.5	5.0	5.0 ±1.5	0.6
	CC45SL3AD150JYGNA	15	± 5	5.5	5.0	5.0 ±1.5	0.6
	CC45SL3AD180JYGNA	18	± 5	5.5	5.0	5.0 ±1.5	0.6
	CC45SL3AD220JYGNA	22	± 5	5.5	5.0	5.0 ±1.5	0.6
	CC45SL3AD270JYGNA	27	± 5	5.5	5.0	5.0 ±1.5	0.6
	CC45SL3AD330JYGNA	33	± 5	5.5	5.0	5.0 ±1.5	0.6
	CC45SL3AD390JYGNA	39	± 5	5.5	5.0	5.0 ±1.5	0.6
	CC45SL3AD470JYGNA	47	± 5	5.5	5.0	5.0 ±1.5	0.6
	CC45SL3AD560JYGNA	56	± 5	5.5	5.0	5.0 ±1.5	0.6
	CC45SL3AD680JYGNA	68	± 5	5.5	5.0	5.0 ±1.5	0.6
	CC45SL3AD820JYGNA	82	± 5	6.0	5.0	5.0 ±1.5	0.6
	CC45SL3AD101JYGNA	100	± 5	6.5	5.0	5.0 ±1.5	0.6
	CC45SL3AD121JYGNA	120	± 5	7.0	5.0	5.0 ±1.5	0.6
	CC45SL3AD151JYGNA	150	± 5	7.5	5.0	5.0 ±1.5	0.6
	CC45SL3AD181JYGNA	180	± 5	8.0	5.0	5.0 ±1.5	0.6
	CC45SL3AD221JYGNA	220	± 5	8.5	5.0	5.0 ±1.5	0.6
	CC45SL3AD271JYGNA	270	± 5	9.0	5.0	5.0 ±1.5	0.6
	CC45SL3AD331JYGNA	330	± 5	10.0	5.0	5.0 ±1.5	0.6
	CC45SL3AD391JYGNA	390	± 5	10.5	5.0	5.0 ±1.5	0.6
	CC45SL3AD471JYGNA	470	± 5	11.5	5.0	7.5 ±1.5	0.6

T.C. _____ : SL
 Rated voltage: DC 1kV

Vertical kink short lead (lead style: N / bulk)

Table-3 Continue

Your part No.	TDK part No.	Cap. (pF)	C-Tol. (%)	Dimension (Unit : mm)			
				D Max.	T Max.	F	φd
	CC45SL3AD100JYNNA	10	± 5	5.5	5.0	5.0 ±1.5	0.6
	CC45SL3AD120JYNNA	12	± 5	5.5	5.0	5.0 ±1.5	0.6
	CC45SL3AD150JYNNA	15	± 5	5.5	5.0	5.0 ±1.5	0.6
	CC45SL3AD180JYNNA	18	± 5	5.5	5.0	5.0 ±1.5	0.6
	CC45SL3AD220JYNNA	22	± 5	5.5	5.0	5.0 ±1.5	0.6
	CC45SL3AD270JYNNA	27	± 5	5.5	5.0	5.0 ±1.5	0.6
	CC45SL3AD330JYNNA	33	± 5	5.5	5.0	5.0 ±1.5	0.6
	CC45SL3AD390JYNNA	39	± 5	5.5	5.0	5.0 ±1.5	0.6
	CC45SL3AD470JYNNA	47	± 5	5.5	5.0	5.0 ±1.5	0.6
	CC45SL3AD560JYNNA	56	± 5	5.5	5.0	5.0 ±1.5	0.6
	CC45SL3AD680JYNNA	68	± 5	5.5	5.0	5.0 ±1.5	0.6
	CC45SL3AD820JYNNA	82	± 5	6.0	5.0	5.0 ±1.5	0.6
	CC45SL3AD101JYNNA	100	± 5	6.5	5.0	5.0 ±1.5	0.6
	CC45SL3AD121JYNNA	120	± 5	7.0	5.0	5.0 ±1.5	0.6
	CC45SL3AD151JYNNA	150	± 5	7.5	5.0	5.0 ±1.5	0.6
	CC45SL3AD181JYNNA	180	± 5	8.0	5.0	5.0 ±1.5	0.6
	CC45SL3AD221JYNNA	220	± 5	8.5	5.0	5.0 ±1.5	0.6
	CC45SL3AD271JYNNA	270	± 5	9.0	5.0	5.0 ±1.5	0.6
	CC45SL3AD331JYNNA	330	± 5	10.0	5.0	5.0 ±1.5	0.6
	CC45SL3AD391JYNNA	390	± 5	10.5	5.0	5.0 ±1.5	0.6
	CC45SL3AD471JYNNA	470	± 5	11.5	5.0	7.5 ±1.5	0.6

T.C. _____ : SL
 Rated voltage: DC 1kV

Vertical kink long lead (lead style: V / Taping)

Table-3 Continue

Your part No	TDK part No.	Cap. (pF)	C-Tol. (%)	Dimension (Unit : mm)				Shape
				D Max.	T Max.	F	φd	
	CC45SL3AD100JYVNA	10	± 5	5.5	5.0	5 +0.8,-0.2	0.6	A
	CC45SL3AD120JYVNA	12	± 5	5.5	5.0	5 +0.8,-0.2	0.6	A
	CC45SL3AD150JYVNA	15	± 5	5.5	5.0	5 +0.8,-0.2	0.6	A
	CC45SL3AD180JYVNA	18	± 5	5.5	5.0	5 +0.8,-0.2	0.6	A
	CC45SL3AD220JYVNA	22	± 5	5.5	5.0	5 +0.8,-0.2	0.6	A
	CC45SL3AD270JYVNA	27	± 5	5.5	5.0	5 +0.8,-0.2	0.6	A
	CC45SL3AD330JYVNA	33	± 5	5.5	5.0	5 +0.8,-0.2	0.6	A
	CC45SL3AD390JYVNA	39	± 5	5.5	5.0	5 +0.8,-0.2	0.6	A
	CC45SL3AD470JYVNA	47	± 5	5.5	5.0	5 +0.8,-0.2	0.6	A
	CC45SL3AD560JYVNA	56	± 5	5.5	5.0	5 +0.8,-0.2	0.6	A
	CC45SL3AD680JYVNA	68	± 5	5.5	5.0	5 +0.8,-0.2	0.6	A
	CC45SL3AD820JYVNA	82	± 5	6.0	5.0	5 +0.8,-0.2	0.6	A
	CC45SL3AD101JYVNA	100	± 5	6.5	5.0	5 +0.8,-0.2	0.6	A
	CC45SL3AD121JYVNA	120	± 5	7.0	5.0	5 +0.8,-0.2	0.6	A
	CC45SL3AD151JYVNA	150	± 5	7.5	5.0	5 +0.8,-0.2	0.6	A
	CC45SL3AD181JYVNA	180	± 5	8.0	5.0	5 +0.8,-0.2	0.6	A
	CC45SL3AD221JYVNA	220	± 5	8.5	5.0	5 +0.8,-0.2	0.6	A
	CC45SL3AD271JYVNA	270	± 5	9.0	5.0	5 +0.8,-0.2	0.6	A
	CC45SL3AD331JYVNA	330	± 5	10.0	5.0	5 +0.8,-0.2	0.6	A
	CC45SL3AD391JYVNA	390	± 5	10.5	5.0	5 +0.8,-0.2	0.6	A
	CC45SL3AD471JYVNA	470	± 5	11.5	5.0	7.5 ±0.8	0.6	B

T.C. _____ : SL
 Rated voltage: DC 2kV

Vertical kink long lead (lead style: G / bulk)

Table-4

Your part No.	TDK part No.	Cap. (pF)	C-Tol. (%)	Dimension (Unit : mm)			
				D Max.	T Max.	F	φd
	CC45SL3DD100JYGNA	10	± 5	5.5	5.0	5.0 ±1.5	0.6
	CC45SL3DD120JYGNA	12	± 5	5.5	5.0	5.0 ±1.5	0.6
	CC45SL3DD150JYGNA	15	± 5	5.5	5.0	5.0 ±1.5	0.6
	CC45SL3DD180JYGNA	18	± 5	5.5	5.0	5.0 ±1.5	0.6
	CC45SL3DD220JYGNA	22	± 5	5.5	5.0	5.0 ±1.5	0.6
	CC45SL3DD270JYGNA	27	± 5	5.5	5.0	5.0 ±1.5	0.6
	CC45SL3DD330JYGNA	33	± 5	5.5	5.0	5.0 ±1.5	0.6
	CC45SL3DD390JYGNA	39	± 5	5.5	5.0	5.0 ±1.5	0.6
	CC45SL3DD470JYGNA	47	± 5	5.5	5.0	5.0 ±1.5	0.6
	CC45SL3DD560JYGNA	56	± 5	6.0	5.0	5.0 ±1.5	0.6
	CC45SL3DD680JYGNA	68	± 5	6.5	5.0	5.0 ±1.5	0.6
	CC45SL3DD820JYGNA	82	± 5	7.0	5.0	5.0 ±1.5	0.6
	CC45SL3DD101JYGNA	100	± 5	7.5	5.0	5.0 ±1.5	0.6
	CC45SL3DD121JYGNA	120	± 5	8.0	5.0	5.0 ±1.5	0.6
	CC45SL3DD151JYGNA	150	± 5	8.5	5.0	5.0 ±1.5	0.6
	CC45SL3DD181JYGNA	180	± 5	9.0	5.0	5.0 ±1.5	0.6
	CC45SL3DD221JYGNA	220	± 5	10.0	5.0	5.0 ±1.5	0.6
	CC45SL3DD271JYGNA	270	± 5	11.0	5.0	7.5 ±1.5	0.6
	CC45SL3DD331JYGNA	330	± 5	11.5	5.0	7.5 ±1.5	0.6
	CC45SL3DD391JYGNA	390	± 5	12.5	5.0	7.5 ±1.5	0.6

T.C. : SL
 Rated voltage: DC 2kV

Vertical kink short lead (lead style: N / bulk)

Table-4 Continue

Your part No.	TDK part No.	Cap. (pF)	C-Tol. (%)	Dimension (Unit : mm)			
				D Max.	T Max.	F	φd
	CC45SL3DD100JYNNA	10	± 5	5.5	5.0	5.0 ±1.5	0.6
	CC45SL3DD120JYNNA	12	± 5	5.5	5.0	5.0 ±1.5	0.6
	CC45SL3DD150JYNNA	15	± 5	5.5	5.0	5.0 ±1.5	0.6
	CC45SL3DD180JYNNA	18	± 5	5.5	5.0	5.0 ±1.5	0.6
	CC45SL3DD220JYNNA	22	± 5	5.5	5.0	5.0 ±1.5	0.6
	CC45SL3DD270JYNNA	27	± 5	5.5	5.0	5.0 ±1.5	0.6
	CC45SL3DD330JYNNA	33	± 5	5.5	5.0	5.0 ±1.5	0.6
	CC45SL3DD390JYNNA	39	± 5	5.5	5.0	5.0 ±1.5	0.6
	CC45SL3DD470JYNNA	47	± 5	5.5	5.0	5.0 ±1.5	0.6
	CC45SL3DD560JYNNA	56	± 5	6.0	5.0	5.0 ±1.5	0.6
	CC45SL3DD680JYNNA	68	± 5	6.5	5.0	5.0 ±1.5	0.6
	CC45SL3DD820JYNNA	82	± 5	7.0	5.0	5.0 ±1.5	0.6
	CC45SL3DD101JYNNA	100	± 5	7.5	5.0	5.0 ±1.5	0.6
	CC45SL3DD121JYNNA	120	± 5	8.0	5.0	5.0 ±1.5	0.6
	CC45SL3DD151JYNNA	150	± 5	8.5	5.0	5.0 ±1.5	0.6
	CC45SL3DD181JYNNA	180	± 5	9.0	5.0	5.0 ±1.5	0.6
	CC45SL3DD221JYNNA	220	± 5	10.0	5.0	5.0 ±1.5	0.6
	CC45SL3DD271JYNNA	270	± 5	11.0	5.0	7.5 ±1.5	0.6
	CC45SL3DD331JYNNA	330	± 5	11.5	5.0	7.5 ±1.5	0.6
	CC45SL3DD391JYNNA	390	± 5	12.5	5.0	7.5 ±1.5	0.6

T.C. : SL
 Rated voltage: DC 2kV

Vertical kink long lead (lead style: V / Taping)

Table-4 Continue

Your part No.	TDK part No.	Cap. (pF)	C-Tol. (%)	Dimension (Unit : mm)				Shape
				D Max.	T Max.	F	φd	
	CC45SL3DD100JYVNA	10	± 5	5.5	5.0	5 +0.8,-02	0.6	A
	CC45SL3DD120JYVNA	12	± 5	5.5	5.0	5 +0.8,-02	0.6	A
	CC45SL3DD150JYVNA	15	± 5	5.5	5.0	5 +0.8,-02	0.6	A
	CC45SL3DD180JYVNA	18	± 5	5.5	5.0	5 +0.8,-02	0.6	A
	CC45SL3DD220JYVNA	22	± 5	5.5	5.0	5 +0.8,-02	0.6	A
	CC45SL3DD270JYVNA	27	± 5	5.5	5.0	5 +0.8,-02	0.6	A
	CC45SL3DD330JYVNA	33	± 5	5.5	5.0	5 +0.8,-02	0.6	A
	CC45SL3DD390JYVNA	39	± 5	5.5	5.0	5 +0.8,-02	0.6	A
	CC45SL3DD470JYVNA	47	± 5	5.5	5.0	5 +0.8,-02	0.6	A
	CC45SL3DD560JYVNA	56	± 5	6.0	5.0	5 +0.8,-02	0.6	A
	CC45SL3DD680JYVNA	68	± 5	6.5	5.0	5 +0.8,-02	0.6	A
	CC45SL3DD820JYVNA	82	± 5	7.0	5.0	5 +0.8,-02	0.6	A
	CC45SL3DD101JYVNA	100	± 5	7.5	5.0	5 +0.8,-02	0.6	A
	CC45SL3DD121JYVNA	120	± 5	8.0	5.0	5 +0.8,-02	0.6	A
	CC45SL3DD151JYVNA	150	± 5	8.5	5.0	5 +0.8,-02	0.6	A
	CC45SL3DD181JYVNA	180	± 5	9.0	5.0	5 +0.8,-02	0.6	A
	CC45SL3DD221JYVNA	220	± 5	10.0	5.0	5 +0.8,-02	0.6	A
	CC45SL3DD271JYVNA	270	± 5	11.0	5.0	7.5 ±0.8	0.6	B
	CC45SL3DD331JYVNA	330	± 5	11.5	5.0	7.5 ±0.8	0.6	B
	CC45SL3DD391JYVNA	390	± 5	12.5	5.0	7.5 ±0.8	0.6	B

T.C. _____ : SL _____

Rated voltage: DC 3kV

Vertical kink long lead (lead style: G / bulk)

Table-5

Your part No.	TDK part No.	Cap. (pF)	C-Tol. (%)	Dimension (Unit : mm)			
				D Max.	T Max.	F	φd
	CC45SL3FD100JYGNA	10	± 5	5.5	6.0	7.5 ±1.5	0.6
	CC45SL3FD120JYGNA	12	± 5	5.5	6.0	7.5 ±1.5	0.6
	CC45SL3FD150JYGNA	15	± 5	5.5	6.0	7.5 ±1.5	0.6
	CC45SL3FD180JYGNA	18	± 5	5.5	6.0	7.5 ±1.5	0.6
	CC45SL3FD220JYGNA	22	± 5	5.5	6.0	7.5 ±1.5	0.6
	CC45SL3FD270JYGNA	27	± 5	5.5	6.0	7.5 ±1.5	0.6
	CC45SL3FD330JYGNA	33	± 5	6.0	6.0	7.5 ±1.5	0.6
	CC45SL3FD390JYGNA	39	± 5	6.0	6.0	7.5 ±1.5	0.6
	CC45SL3FD470JYGNA	47	± 5	6.5	6.0	7.5 ±1.5	0.6
	CC45SL3FD560JYGNA	56	± 5	7.0	6.0	7.5 ±1.5	0.6
	CC45SL3FD680JYGNA	68	± 5	7.5	6.0	7.5 ±1.5	0.6
	CC45SL3FD820JYGNA	82	± 5	8.0	6.0	7.5 ±1.5	0.6
	CC45SL3FD101JYGNA	100	± 5	8.5	6.0	7.5 ±1.5	0.6
	CC45SL3FD121JYGNA	120	± 5	9.5	6.0	7.5 ±1.5	0.6
	CC45SL3FD151JYGNA	150	± 5	10.0	6.0	7.5 ±1.5	0.6
	CC45SL3FD181JYGNA	180	± 5	11.0	6.0	7.5 ±1.5	0.6
	CC45SL3FD221JYGNA	220	± 5	12.0	6.0	7.5 ±1.5	0.6

T.C. _____ : SL
 Rated voltage: DC 3kV

Vertical kink short lead (lead style: N / bulk)

Table-5 Continue

Your part No.	TDK part No.	Cap. (pF)	C-Tol. (%)	Dimension (Unit : mm)			
				D Max.	T Max.	F	φd
	CC45SL3FD100JYNNA	10	± 5	5.5	6.0	7.5 ±1.5	0.6
	CC45SL3FD120JYNNA	12	± 5	5.5	6.0	7.5 ±1.5	0.6
	CC45SL3FD150JYNNA	15	± 5	5.5	6.0	7.5 ±1.5	0.6
	CC45SL3FD180JYNNA	18	± 5	5.5	6.0	7.5 ±1.5	0.6
	CC45SL3FD220JYNNA	22	± 5	5.5	6.0	7.5 ±1.5	0.6
	CC45SL3FD270JYNNA	27	± 5	5.5	6.0	7.5 ±1.5	0.6
	CC45SL3FD330JYNNA	33	± 5	6.0	6.0	7.5 ±1.5	0.6
	CC45SL3FD390JYNNA	39	± 5	6.0	6.0	7.5 ±1.5	0.6
	CC45SL3FD470JYNNA	47	± 5	6.5	6.0	7.5 ±1.5	0.6
	CC45SL3FD560JYNNA	56	± 5	7.0	6.0	7.5 ±1.5	0.6
	CC45SL3FD680JYNNA	68	± 5	7.5	6.0	7.5 ±1.5	0.6
	CC45SL3FD820JYNNA	82	± 5	8.0	6.0	7.5 ±1.5	0.6
	CC45SL3FD101JYNNA	100	± 5	8.5	6.0	7.5 ±1.5	0.6
	CC45SL3FD121JYNNA	120	± 5	9.5	6.0	7.5 ±1.5	0.6
	CC45SL3FD151JYNNA	150	± 5	10.0	6.0	7.5 ±1.5	0.6
	CC45SL3FD181JYNNA	180	± 5	11.0	6.0	7.5 ±1.5	0.6
	CC45SL3FD221JYNNA	220	± 5	12.0	6.0	7.5 ±1.5	0.6

T.C. _____ : SL
 Rated voltage: DC 3kV

Vertical kink long lead (lead style: V / Taping)

Table-5 Continue

Your part No.	TDK part No.	Cap. (pF)	C-Tol. (%)	Dimension (Unit : mm)				Shape
				D Max.	T Max.	F	φd	
	CC45SL3FD100JYVNA	10	± 5	5.5	6.0	7.5 ±0.8	0.6	B
	CC45SL3FD120JYVNA	12	± 5	5.5	6.0	7.5 ±0.8	0.6	B
	CC45SL3FD150JYVNA	15	± 5	5.5	6.0	7.5 ±0.8	0.6	B
	CC45SL3FD180JYVNA	18	± 5	5.5	6.0	7.5 ±0.8	0.6	B
	CC45SL3FD220JYVNA	22	± 5	5.5	6.0	7.5 ±0.8	0.6	B
	CC45SL3FD270JYVNA	27	± 5	5.5	6.0	7.5 ±0.8	0.6	B
	CC45SL3FD330JYVNA	33	± 5	6.0	6.0	7.5 ±0.8	0.6	B
	CC45SL3FD390JYVNA	39	± 5	6.0	6.0	7.5 ±0.8	0.6	B
	CC45SL3FD470JYVNA	47	± 5	6.5	6.0	7.5 ±0.8	0.6	B
	CC45SL3FD560JYVNA	56	± 5	7.0	6.0	7.5 ±0.8	0.6	B
	CC45SL3FD680JYVNA	68	± 5	7.5	6.0	7.5 ±0.8	0.6	B
	CC45SL3FD820JYVNA	82	± 5	8.0	6.0	7.5 ±0.8	0.6	B
	CC45SL3FD101JYVNA	100	± 5	8.5	6.0	7.5 ±0.8	0.6	B
	CC45SL3FD121JYVNA	120	± 5	9.5	6.0	7.5 ±0.8	0.6	B
	CC45SL3FD151JYVNA	150	± 5	10.0	6.0	7.5 ±0.8	0.6	B
	CC45SL3FD181JYVNA	180	± 5	11.0	6.0	7.5 ±0.8	0.6	B
	CC45SL3FD221JYVNA	220	± 5	12.0	6.0	7.5 ±0.8	0.6	B

Flow soldering recommended condition

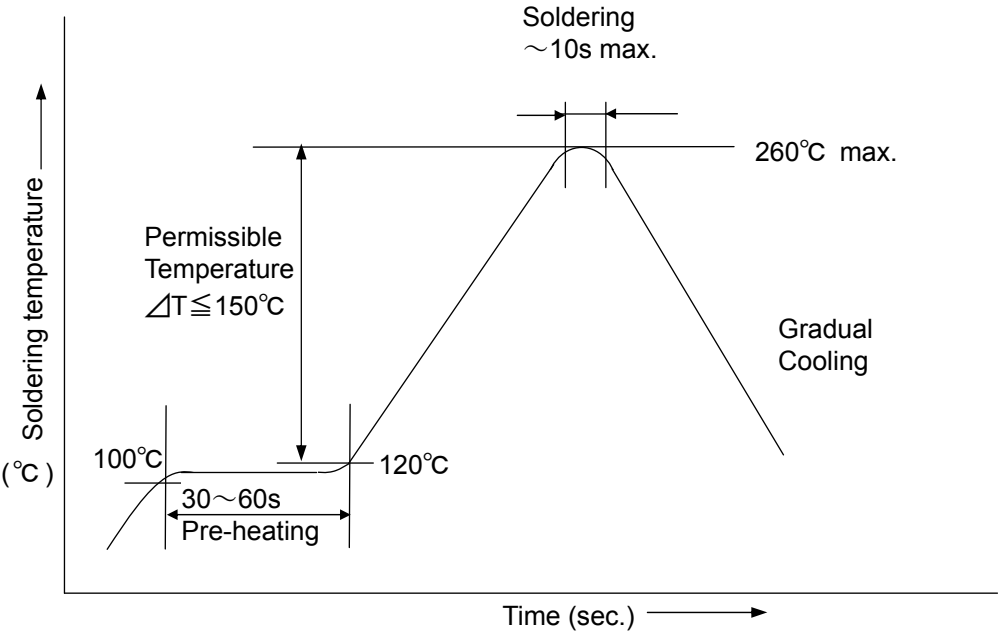

Fig-1